

Spring  
2002

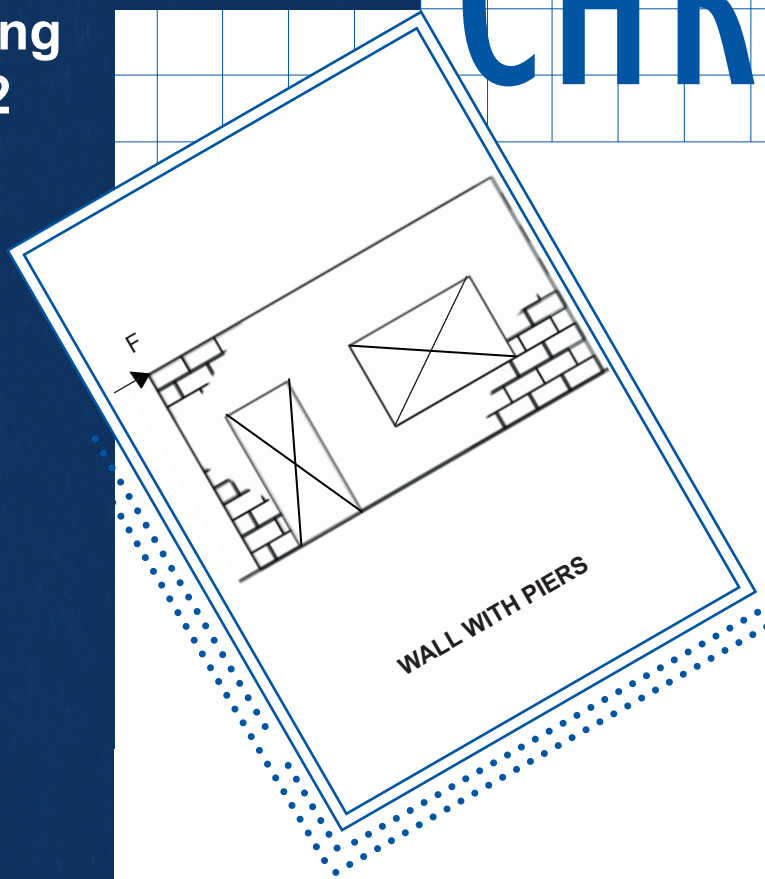

## DESIGN OF MASONRY PIERS

### INTRODUCTION

Masonry piers typically occur in shear walls that have perforations such as openings for doors or windows. Their design is similar to the design of walls and columns. However, because of the geometric configuration of piers, there are certain aspects of the design that warrant further discussion. This issue of "Masonry Chronicles" will study the design of piers and provide an example that illustrates the strength design procedures of the 1997 Uniform Building Code (UBC). The issues that will be discussed are as follows:

- Distribution of lateral loads to adjacent piers
- Design of piers for in-plane forces

### Distribution of Lateral Loads to Piers

Lateral loads are distributed to piers in proportion to their stiffnesses or rigidity. Thus calculations need to be performed to obtain the relative stiffnesses of the piers in a wall.

For a pier that is fixed against rotation at the top and bottom supports, the displacement, " $\Delta$ ," due to a lateral force,  $F$  is given by the following equation:

$$\Delta = \frac{Fh^3}{12EI} + \frac{1.2Fh}{GA} \quad (1)$$

where  $E$  is the modulus of elasticity,  $G$  is the shear modulus,  $h$  is the height of the pier, and  $A$  and  $I$  are the area and moment of inertia of the pier cross section, respectively. For masonry, we can assume that  $G = 0.4E$ . Then, using the appropriate relationships for the pier geometric properties:

$$A = Lt ; \quad I = \frac{tL^3}{12}$$

where  $L$  and  $t$  are the length and thickness of the masonry pier, respectively, the displacement a pier subjected to a unit load at the top is given by:

$$\ddot{A} = \frac{1}{Et} \left[ \left( \frac{h}{L} \right)^3 + 3 \left( \frac{h}{L} \right) \right] \quad (2)$$

Since we are only concerned with the *relative* stiffness of the piers, we can assume arbitrary values for  $E$  and  $t$ . Assuming that  $E = 1$  and  $t = 1$ , the relative rigidity,  $R$ , of each masonry wall, which is the inverse of the displacement due to a unit load, is given by:

$$R = \frac{1}{\Delta} = \left[ \left( \frac{h}{L} \right)^3 + 3 \left( \frac{h}{L} \right) \right]^{-1} \quad (3)$$

For a cantilever pier, which is free to rotate at the top, the corresponding rigidity is given by:

$$R = \frac{1}{\Delta} = \left[ 4 \left( \frac{h}{L} \right)^3 + 3 \left( \frac{h}{L} \right) \right]^{-1} \quad (4)$$

### Design for In-Plane Loads

The design of piers subjected to in-plane forces is similar to the design of columns and walls in that they are considered as elements that resist both in-plane axial loads and in-plane flexural loads. The strength design provisions of the 1997 UBC stipulate specific constraints on the dimensions and reinforcement details of piers. It is the author's recommendation that piers designed using the working stress method also adhere to these requirements.

#### Dimensional Limits (Section 2108.2.3.9)

- The nominal width of a pier shall not be less than 6 inches
- The distance between lateral supports of a pier shall not exceed 30 times the nominal width of the pier except as provided for below:
  1. When the distance between lateral supports of a pier exceeds 30 times the nominal width of the pier, the provisions of Section 2108.2.4 (Wall design for out-of-plane forces) shall be used for design.
- The nominal length of a pier shall not be less than three times the nominal width of the pier and shall not be greater than six times the nominal width of the pier.
- The clear height of a pier shall not exceed five times the nominal length of the pier, except that the length of a pier may be equal to the width of a pier when the axial force at the location of maximum moment is less than  $0.04f'_m A_g$ .

#### Reinforcement Details (Section 2108.2.3.11)

- A pier subjected to in-plane stress reversals shall have symmetric longitudinal reinforcement.
- At least one longitudinal bar shall be provided in the end cells
- The minimum longitudinal reinforcement ratio shall be 0.0007
- Transverse reinforcement shall be provided when the factored shear, which is based on the Maximum Inelastic Response Displacement, exceeds shear capacity of the *masonry* alone.

- The minimum transverse reinforcement ratio shall be 0.0015
- Shear reinforcement shall be hooked around the extreme longitudinal bars with a 180-degree hook. Alternatively, at wall intersections, transverse reinforcement with a 90-degree standard hook around a vertical bar in the intersecting wall shall be permitted.

Note also that Section 2108.2.3.11.1 stipulates that the factored axial compression on piers shall not exceed  $0.03A_e f'_m$ .

### Design Example

The wall shown in Figure 1 resists a lateral earthquake load of 50 kips.

- Calculate the shear in the wall piers
- Design Pier 3 for the calculated in plane earthquake forces assuming the building is located at a site with a seismic coefficient  $C_a = 0.48$ .

#### Materials

Masonry: 8-inch thick normal weight (84 psf) fully grouted  
 $f'_m = 1500$  psi

Reinforcing Steel: Grade 60

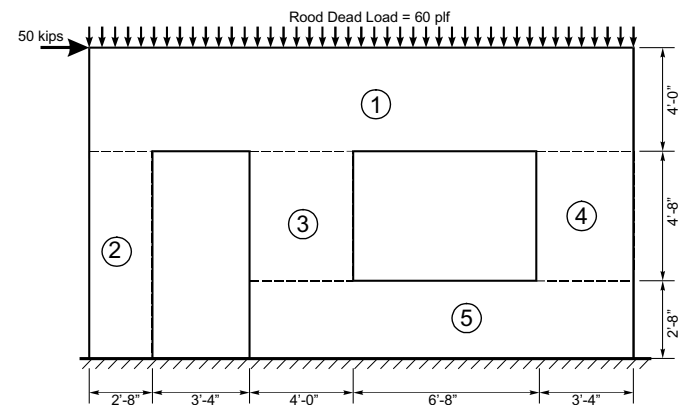

Figure 1 Example Masonry Wall with Piers

#### Distribution of Lateral Loads to Piers

All piers except Pier 1 can be considered as fixed against rotation at the top and bottom. Table 1 provides the calculations for the rigidities of the various piers.

**Table 1 Relative Rigidities of Piers**

	h	L	h/L	R
1	4.0	20.0	0.20	1.58
2	7.3	2.7	2.70	0.04
3	4.7	4.0	1.18	0.19
4	4.7	3.3	1.42	0.14
5	2.7	12.0	0.23	1.46

For piers that are in parallel the total rigidity is equal to the sum of the individual pier rigidities:

$$R_n = \sum_{i=1}^n R_i \quad (5)$$

For piers that are in series the relationship for total rigidity is given by:

$$\frac{1}{R_{A+B}} = \frac{1}{R_A} + \frac{1}{R_B} \quad (6)$$

where A and B are two piers.

The load in each pier is calculated by considering the load path of the lateral load at the top of the wall. At the top of the wall, Pier 1 resists the entire load. Thus:

$$V_{u1} = 50 \text{ kips}$$

At the window opening level, load is distributed between Pier 2 and the combination of Piers 3, 4 and 5.

$$R_2 = 0.04$$

$$R_{3+4+5} = \frac{(R_3 + R_4)R_5}{R_3 + R_4 + R_5} = \frac{(0.19 + 0.14)1.46}{0.19 + 0.14 + 1.46} = 0.27$$

Therefore the shear in the various piers is equal to:

$$V_2 = \left( \frac{0.04}{0.04 + 0.27} \right) 50 = 6.5 \text{ kips}$$

$$V_{3+4+5} = \left( \frac{0.27}{0.04 + 0.27} \right) 50 = 43.5 \text{ kips}$$

Similarly, the shear in Piers 3 and 4 are given by:

$$V_3 = \left( \frac{0.19}{0.19 + 0.14} \right) 43.5 = 25 \text{ kips}$$

$$V_4 = \left( \frac{0.14}{0.19 + 0.14} \right) 43.5 = 18.5 \text{ kips}$$

$$V_5 = 43.5 \text{ kips}$$

Design Pier 3 for In-Plane Loads

The load combinations to be considered for earthquake loads are as follows

$$1.2D + E$$

$$0.9D + E$$

where  $E = E_h \pm E_v$  and  $E_v$  is equal to  $0.5C_a/D$ . Note that the 1.1 factor in Section 1612.2.1 of the 1997 UBC is not included in the load combinations, as recommended by the Structural Engineers Association of California (SEAOC). The load combination then becomes :

$$1.2D + E_h + 0.5(0.48)(1.0)D = 1.44D + E_h$$

$$0.9D + E_h - 0.5(0.48)(1.0)D = 0.66D + E_h$$

Figure 2 shows the tributary area of the pier for gravity loads. The first load combination, which represents the maximum axial load, is evaluated at the bottom of the pier. The axial load is thus

$$P_{u1} = 1.44 [60(9) + 84(9)(4) + 84(4)(4.67)] = 7392 \text{ lbs}$$

The second load combination, which represents the minimum axial load, is evaluated at the top of the pier. The axial load for this load combination is equal to:

$$P_{u2} = .66 [60(9) + 84(9)(4)] = 2352 \text{ lbs}$$

The bending moment for both load combinations is equal to

$$M_u = \frac{Vh}{2} = \frac{25(4.67)}{2} = 58.4 \text{ kip-ft}$$

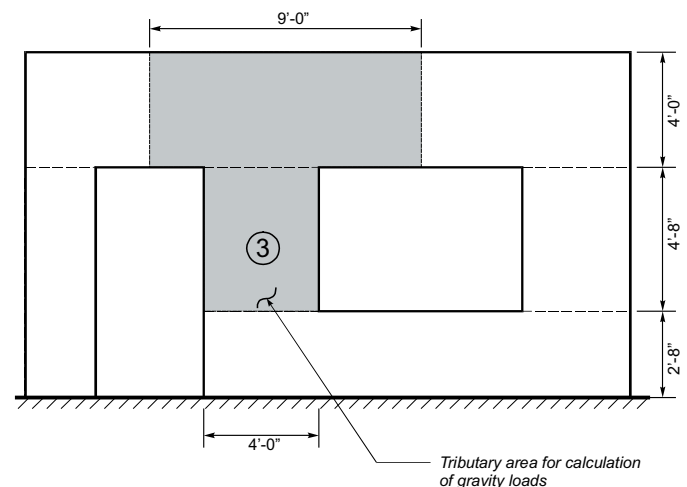

**Figure 2 Tributary Area for Pier 3 Gravity Loads**

Figure 3 shows a cross-section of the pier with the longitudinal wall reinforcement. The selected design will now be checked to see if it can resist the required loads.

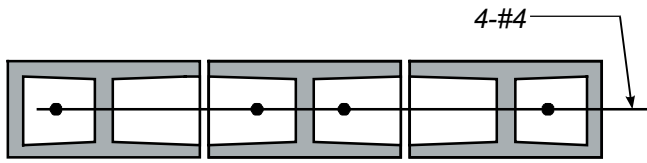

Figure 3 Selected Reinforcement for Pier

To obtain the moment capacity of the pier under various axial loads, an axial load-moment interaction diagram of the wall with the selected reinforcement has to be created. For simplicity, three control points will be located on the interaction diagram (see Figure 6). This is a conservative approximation, and a more accurate curve can be obtained by calculating more points on the interaction diagram.

With no moment on pier (Control Point 1) the nominal axial load capacity of the pier is given by (Section 2108.2.1.2):

$$\begin{aligned}
 P_n &= 0.80 [0.85f'_m (A_c - A_s) + A_s F_y] \\
 &= 0.80 [0.85 (1.5) (48 \times 7.625 - 0.8) + 0.8 (60)] \\
 &= 411 \text{ kips}
 \end{aligned}$$

From Section 2108.1.4.1, the capacity reduction factor is given by:

$$\phi = 0.8 - \frac{P_u}{A_s f'_m} = 0.8 - \frac{411}{(7.63)(48)(1.5)} = 0.05$$

Therefore  $\phi = 0.6$ . For Control Point 2, which has no axial load, we iterate to obtain the neutral axis of the section so that the sum of vertical forces equals zero. A rectangular compressive stress block, with a maximum usable compressive strain of 0.003 is used for the masonry, as stipulated in Section 2108.2.1.2 of the UBC. Figure 4 shows that the depth of the neutral axis for this condition is equal to 4.24 inches.

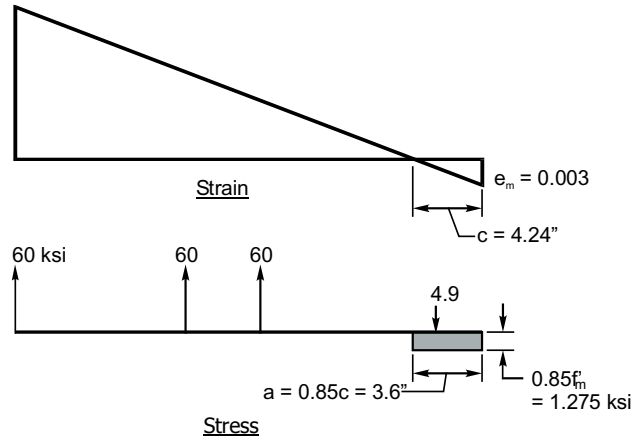

Figure 4 Strain and Stress on Pier with no Axial Load (Control Point 2)

Taking moments about the centerline of the pier:

$$\begin{aligned}
 M_n &= -60 (0.2) (-20) - 60 (0.2) (-4) - 60 (0.2) (4) + 4.9 (0.2) (20) \\
 &\quad + 0.85 (1.5) (7.63) (3.6) \left( 24 - \frac{3.6}{2} \right) \\
 &= 1037 \text{ kip-in} (86.4 \text{ kip-ft})
 \end{aligned}$$

The capacity reduction factor at this axial load is equal to 0.80.

At the balanced strain condition (Control Point 3), the strain in the extreme compressive fiber is equal to 0.003 and the extreme reinforcing steel is just yielding as shown in Figure 5. The depth of the neutral axis from the extreme compression fiber  $c_b$  is given by:

$$c_b = \frac{0.003}{0.003 + 0.00207} (44) = 26 \text{ in}$$

Checking the equilibrium of the wall cross-section with the given neutral axis location, the balanced axial load is found to be 218 kips and the balanced moment is 274 kip-ft. The capacity reduction factor is equal to 0.6 at the balanced condition. Figure 6 shows the interaction diagram for the wall using the three control points obtained. The Figure also shows that the section is adequate for the combined axial load and bending moment at both load combinations.

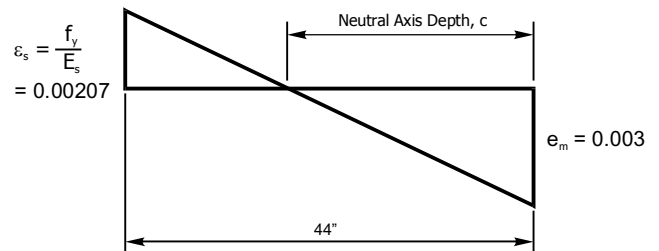
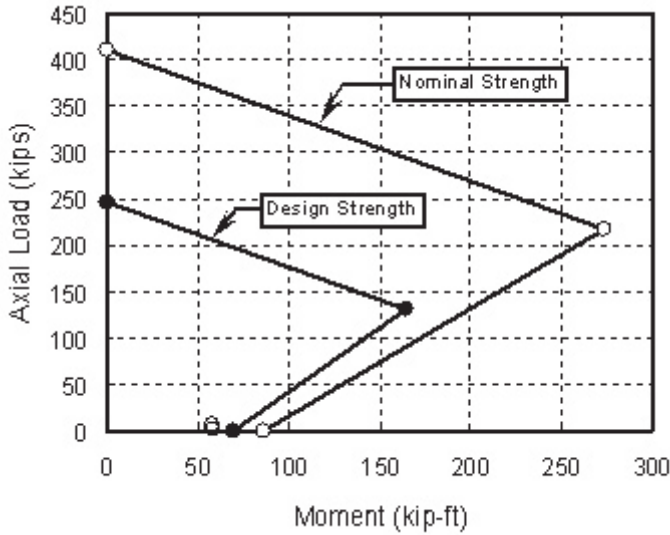

Figure 5 Strain Profile at Balanced Strain Condition



**Figure 6 Interaction Diagram for Pier**

Section 2108.2.3.11.3 stipulates that piers should be designed to resist the shear at the Maximum Inelastic Response Displacement,  $\Delta_m$ . One way to satisfy this design criterion is to design the wall to resist the maximum shear that can be developed based on the moment capacity of the pier.

For the example being considered here, the nominal moment capacity at the maximum axial load of 7.4 kips is equal to:

$$M = 8.4 + \frac{7.4}{218}(274 - 8.4) = 2.8 \text{ kip-ft}$$

and the corresponding shear is:

$$V_u = \frac{2M}{h} = \frac{2(2.8)}{4.8} = 9.7 \text{ kips}$$

If we try #5 bars spaced at 16-inches on center for the transverse reinforcement, the transverse reinforcement ratio is equal to:

$$\rho_v = \frac{0.3}{6(7.6)} = 0.0025$$

The shear capacity is given by:

$$\begin{aligned} \phi V_n &= \phi (V_m + V_s) = \phi \left( C_d A_m \sqrt{f'_m} + A_m \rho_n f_y \right) \\ &= 0.6 \left\{ \frac{1.2}{1000} (8 \times 7.6) \sqrt{1500} + (8 \times 7.6) (0.0025) 6 \right\} \\ &= 42.3 \text{ kips OK} \end{aligned}$$

## Conclusions

The design of piers is similar to the design of walls and columns, with the additional requirement that the relative rigidities of piers need to be calculated in order to distribute the lateral loads to the various piers in a wall. The shear demand on a pier is dependent on the moment capacity. It is therefore disadvantageous to over design a pier by providing excessive flexural reinforcement since this only increase the amount of transverse steel that is required to resist the shear demands.

*This issue of "Masonry Chronicles" was written by Dr. Chukwuma Ekwueme of the Hart Weidlinger Group.*

*"Masonry Chronicles" is a publication of the Concrete Masonry Association of California and Nevada.*

**Reproduction is expressly prohibited without written permission from CMACN.**

*Please contact the Association Executive Director, Dr. Vilas Mujumdar, with any comments or suggestions for future issues.*

Additional "Masonry Chronicles" may also be seen on the CMACN website at <http://www.cmacn.org>

### CMACN ACTIVE MEMBERS

Active Members are an individual, partnership, or corporation which is actively engaged in the manufacture and sale of concrete masonry units.

◆ Angelus Block Company, Inc.  
◆ Basalite  
◆ Blocklite  
◆ Calstone  
◆ Crystalite Block Corporation

◆ Desert Block Co., Inc.  
◆ McNear Brick & Block  
◆ Orco Block Company  
◆ RCP Block & Brick, Inc.  
◆ Valley Block Company

---

---

## MASONRY CHRONICLES CD



- Ten years (1990-2000) of "Masonry Chronicles" on one CD!
- 200 pages of usable technical design information at your fingertips developed by experts over a period of ten years.
- Cost - \$25.00 (\$25.00 plus sales tax (\$1.94) and shipping \$4.40 for a total cost of \$31.44).
- Visa and MasterCard accepted.
- Call (916) 722-1700 or fax (916) 722-1819 to order your copy today.
- Checks payable to CMACN mail to:  
6060 Sunrise Vista Drive, Suite 1990  
Citrus Heights, CA 95610.